

 sphero<sup>®</sup>

littleBits<sup>®</sup>

MEET THE BITS<sup>®</sup> CHALLENGES

# littleBits<sup>®</sup> INVENTION CYCLE

**The Invention Cycle** is a roadmap for your invention journey. Each phase helps you explore your ideas and develop your invention.

**CREATE:** Put something together.

**PLAY:** Use it!

**REMIX:** Improve your Invention.

**SHARE:** Inspire others.

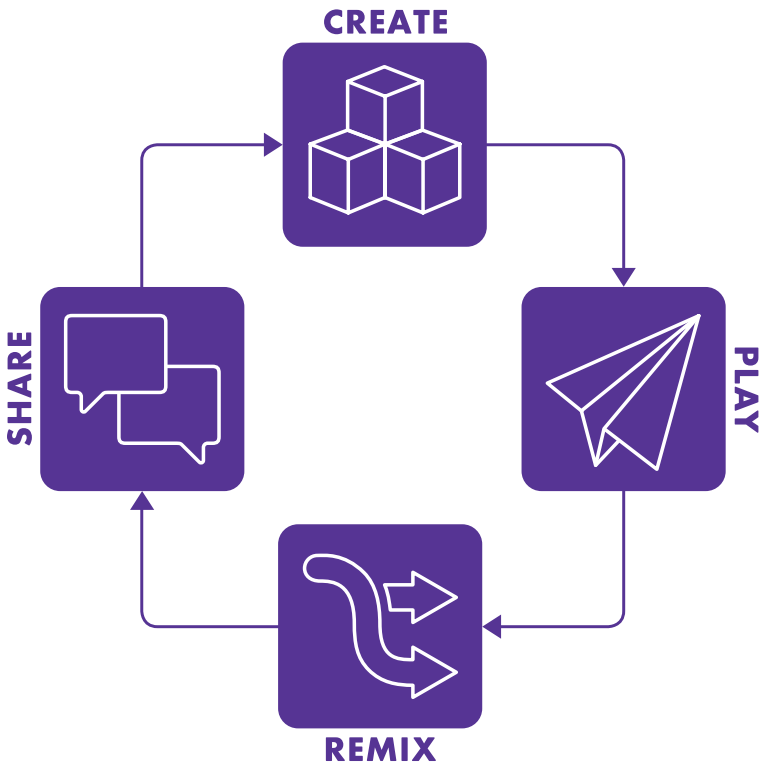

MEET THE BITS 1

# Make a Circuit!

Explore how to make a circuit with littleBits!



## CREATE

Make a circuit!

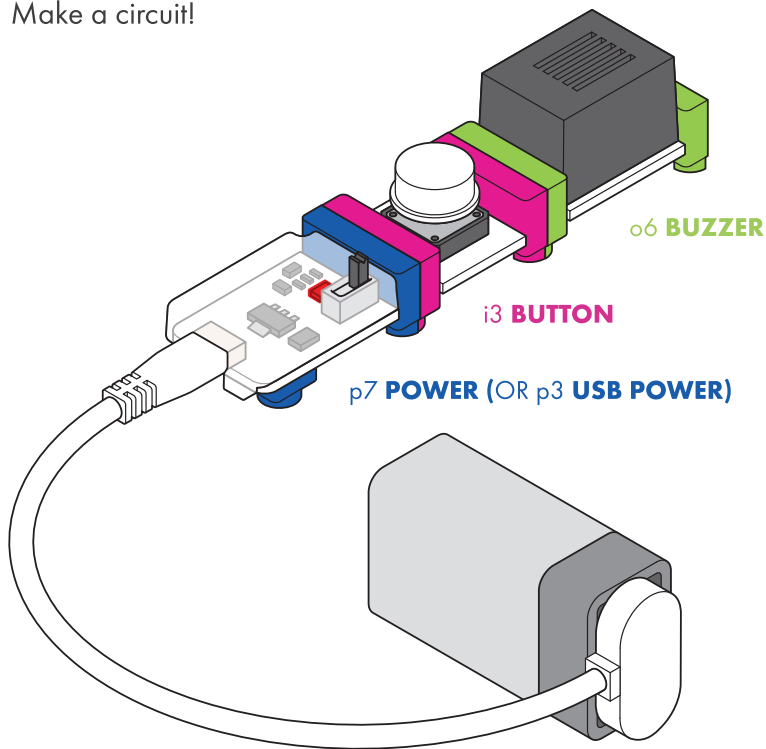



## PLAY

**Switch** the button and the buzzer and see what happens!

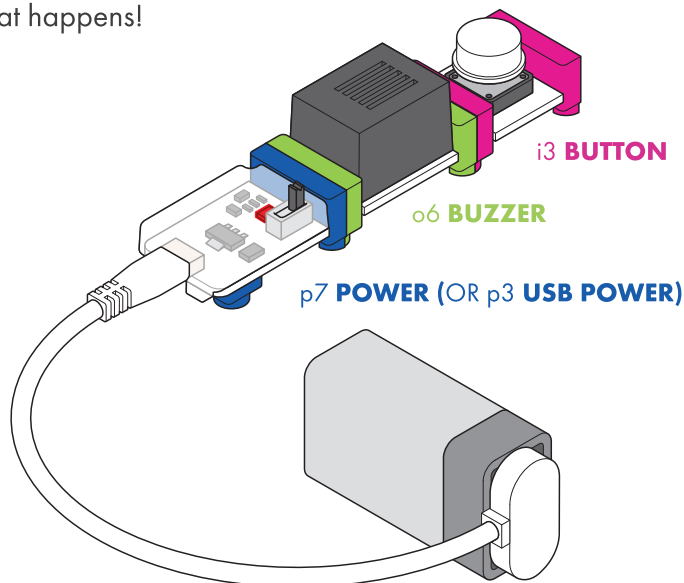

## REMIX

Can you find a **pink Bit** that makes the buzzer louder or quieter?!



## SHARE

Tell someone else what you learned about the **order of Bits** when building circuits.

MEET THE BITS 2

# Inputs and Outputs

Explore different input and output Bits.



## CREATE

Make a circuit!

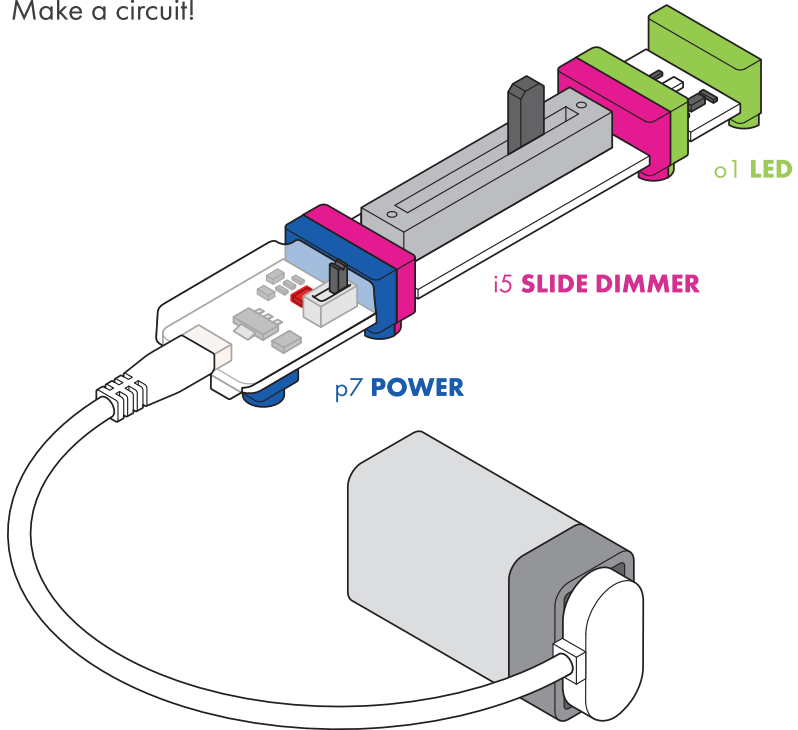



# PLAY

Swap out **pink** **input Bits** to see different behaviors.

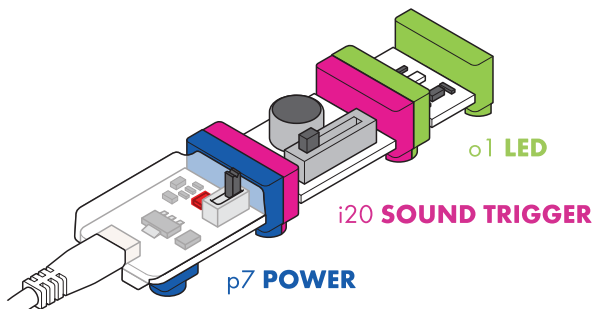
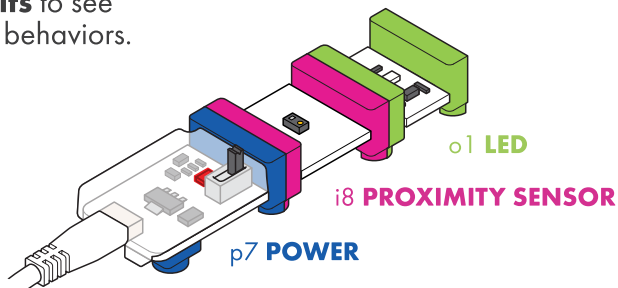

# REMIX

Add more than one **green** **output Bit** and see how many you can put in!



# SHARE

Tell someone else what you learned about the **input and output Bits!**

MEET THE BITS 3

# Light it Up

*Make the RGB LED Bit show any color you like!*



## CREATE

Make a circuit!

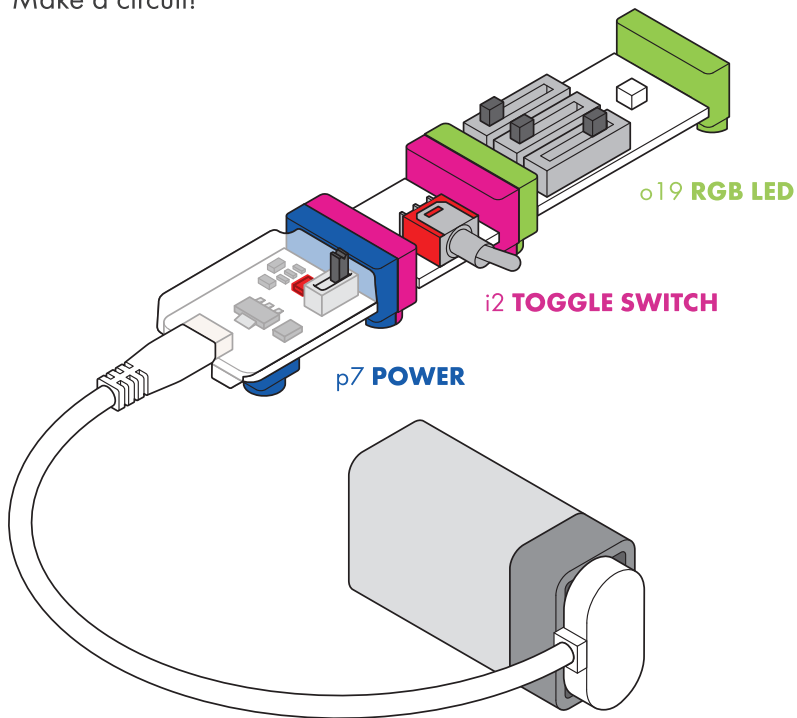



# PLAY

Adjust the **sliders** to make the **RGB LED**:

blue  
green  
red  
yellow  
white

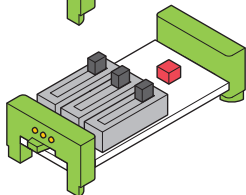
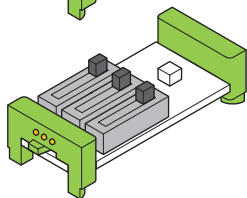
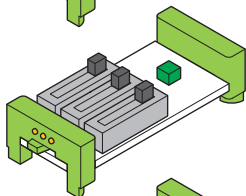
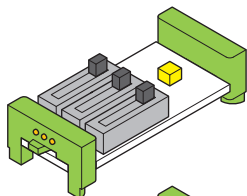
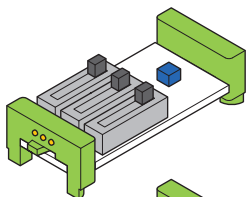

# REMIX

Make a color and see if another group can match it without seeing where the sliders are.



# SHARE

Tell someone else how you **adjusted** the **RGB LED Bit** to make your favorite color!

MEET THE BITS 4

# Motor Modes

*Build a circuit with the DC motor Bit and learn about the different motor modes.*



## CREATE

Make a circuit!

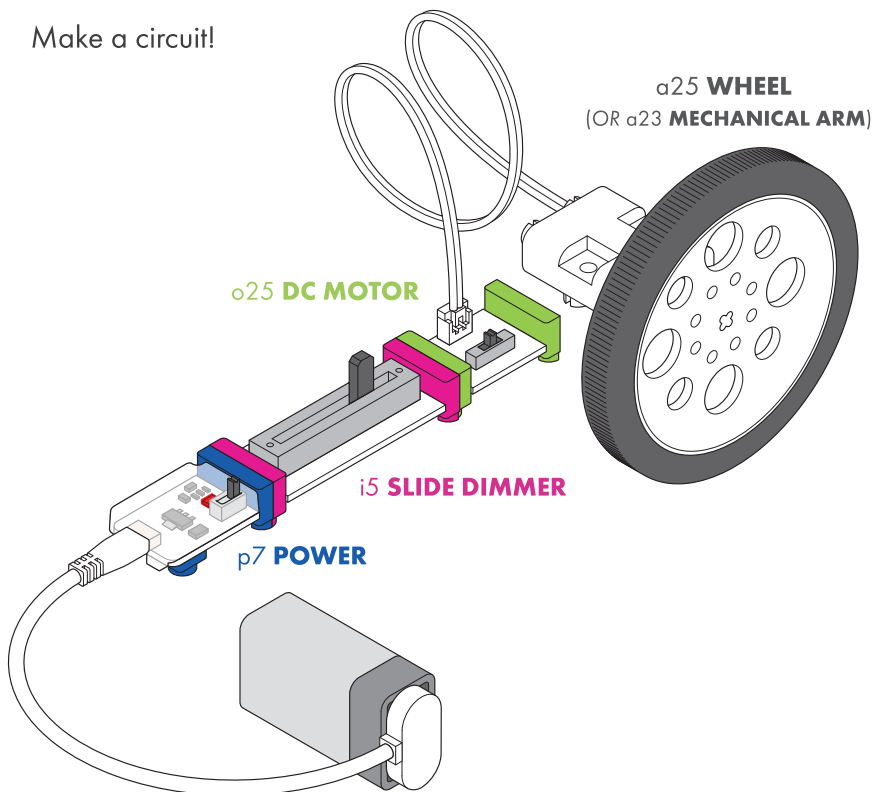



## PLAY

Switch the **mode** on the **DC motor** and see what is different about each mode.

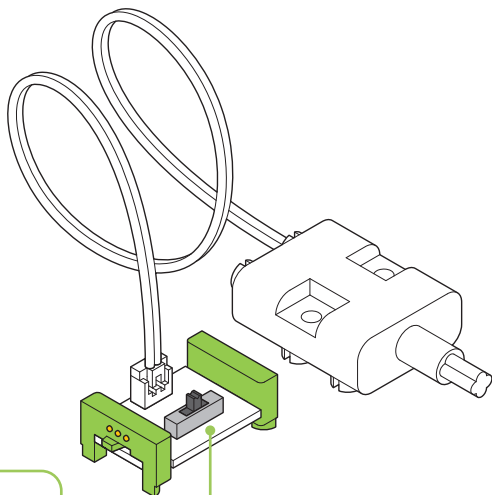

### MODE:

CW (clockwise)

VAR (variable)

CCW (counterclockwise)



## REMIX

**Attach** some **accessories** to the end of the **DC motor** and see what you can make.



## SHARE

Share what you built with the **DC motor** with someone else and explain how it works!

MEET THE BITS 5

# Servo Showtime

*Build an invention with the servo Bit.*



**CREATE**

Make a circuit!

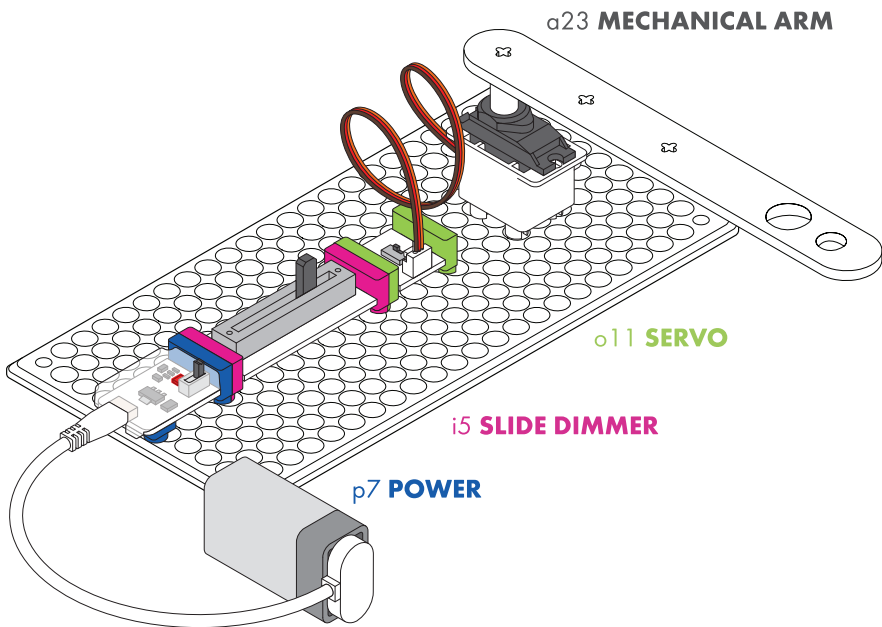



## PLAY

Switch between **SWING** and **TURN mode** and see what is different about each mode.

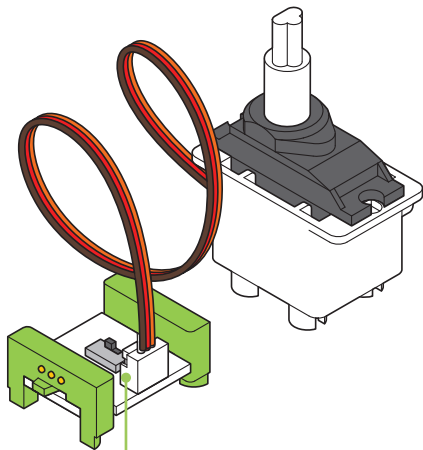

**MODE:** turn or swing



## REMIX

**Attach** some **accessories** to the **servo** and make a waving hand.



## SHARE

Share what you built with the **servo** and explain how you chose the mode.

MEET THE BITS 6

# Inverter & Latch Mashup

*Build some circuits with the latch and the inverter and figure out how they work.*



## CREATE

Make a circuit!

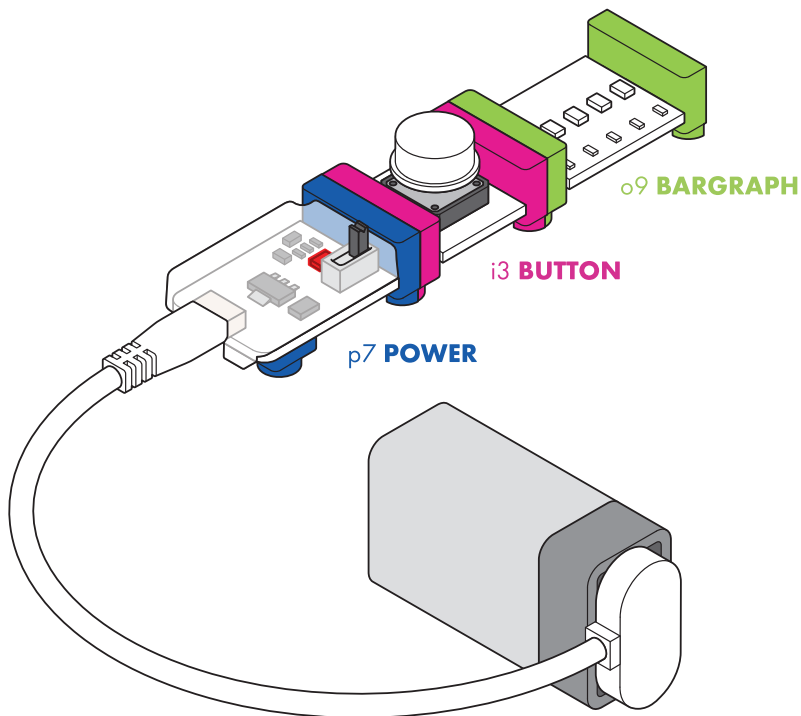



# PLAY

Add in the **latch** and/or the **inverter Bit**.

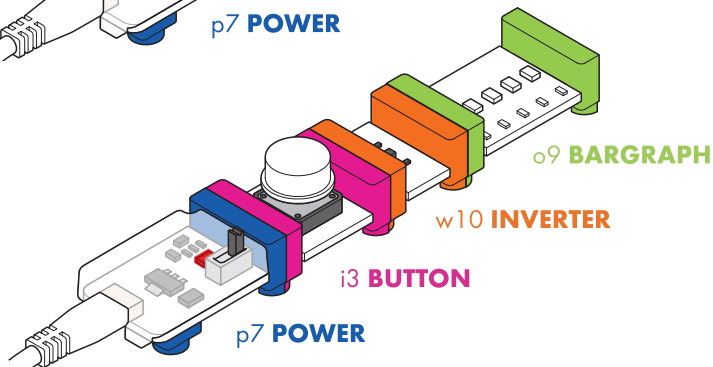
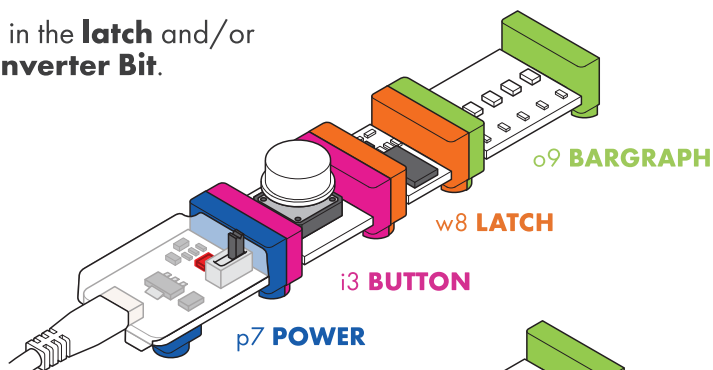

# REMIX

Use the **inverter** and **latch** to create your own **invention!** Maybe an alarm that goes off when a book gets taken off a table.



# SHARE

Tell someone else what you learned about the **inverter** and **latch Bits!**

MEET THE BITS 7

# Digit Discovery

*Build some circuits with the number Bit and explore its different modes!*



## CREATE

Make a circuit!

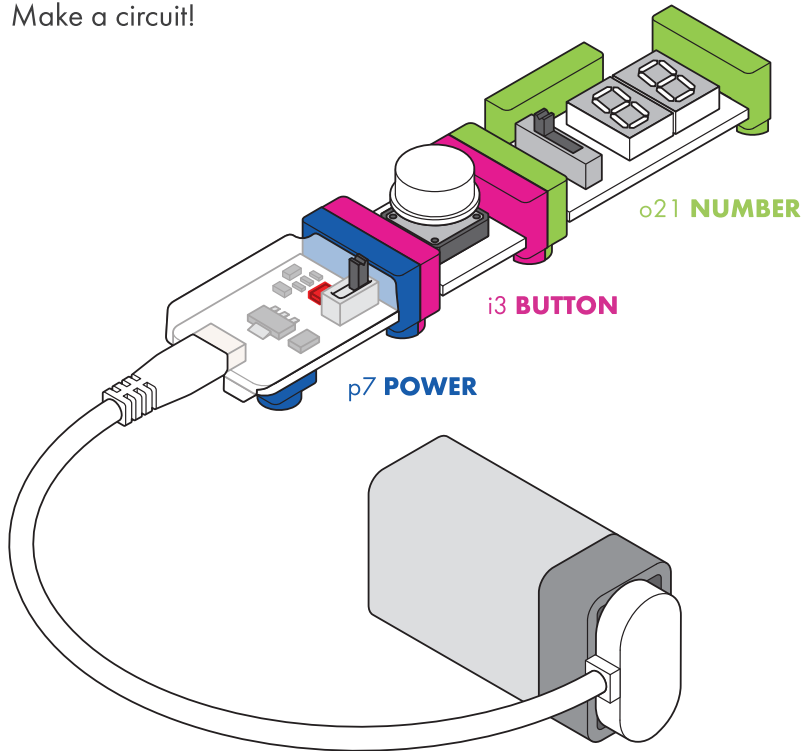



## PLAY

Switch between the four **modes** on the **number Bit**.

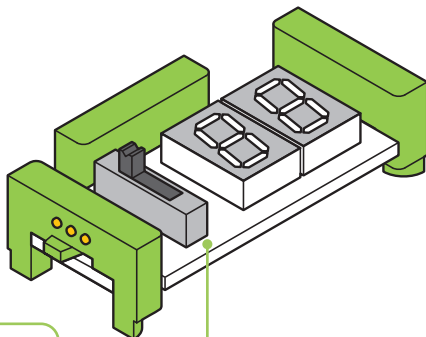

### MODE:

- count up
- count down
- read value
- read volts



## REMIX

Connect a **button** to the **reset** on the number Bit, and see what happens.



## SHARE

Tell someone else what you learned about the **number Bit**!

MEET THE BITS 8

# Sensors

*Build a circuit to explore different sensors!*



## CREATE

Make a circuit with the number Bit in VALUE mode.

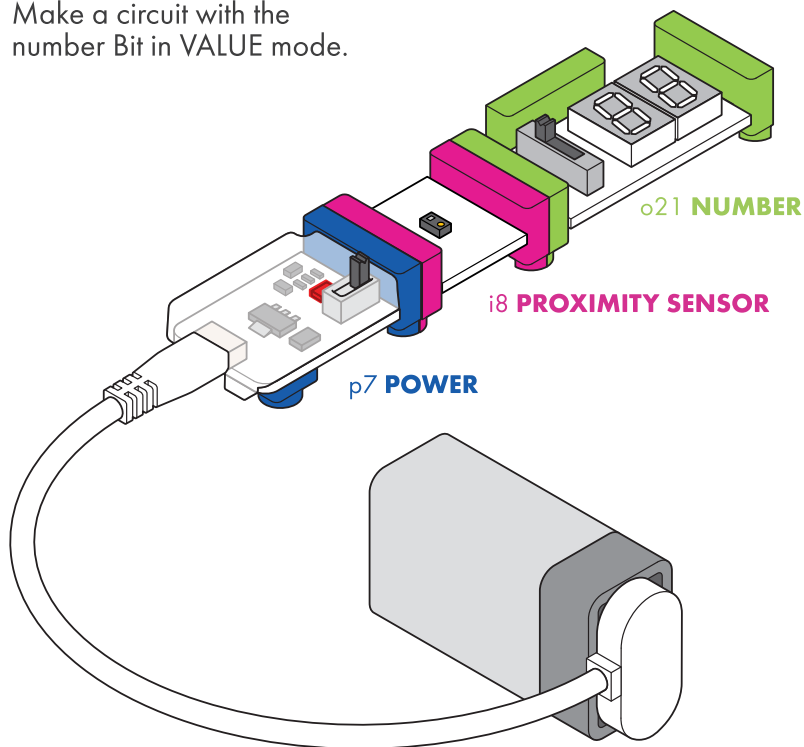



# PLAY

Replace the proximity Bit with the **temperature sensor**, **light sensor**, and the **sound trigger**.

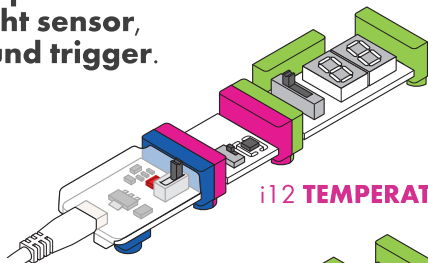

i12 **TEMPERATURE SENSOR**

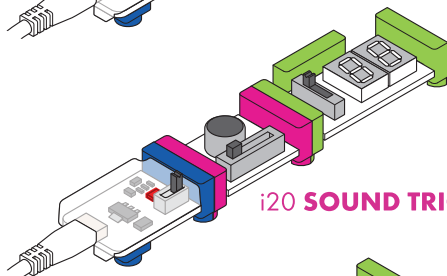

i20 **SOUND TRIGGER**

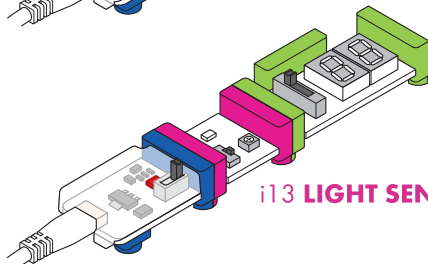

i13 **LIGHT SENSOR**



# REMIX

Choose a **sensor** (e.g. light, sound, temperature, etc.) and make an invention that showcases it.



# SHARE

Tell someone else what you learned about the **sensor Bits!**

MEET THE BITS 9

# Setting Thresholds

Explore the threshold Bit and use it in a circuit you design!



**CREATE**

Make a circuit!

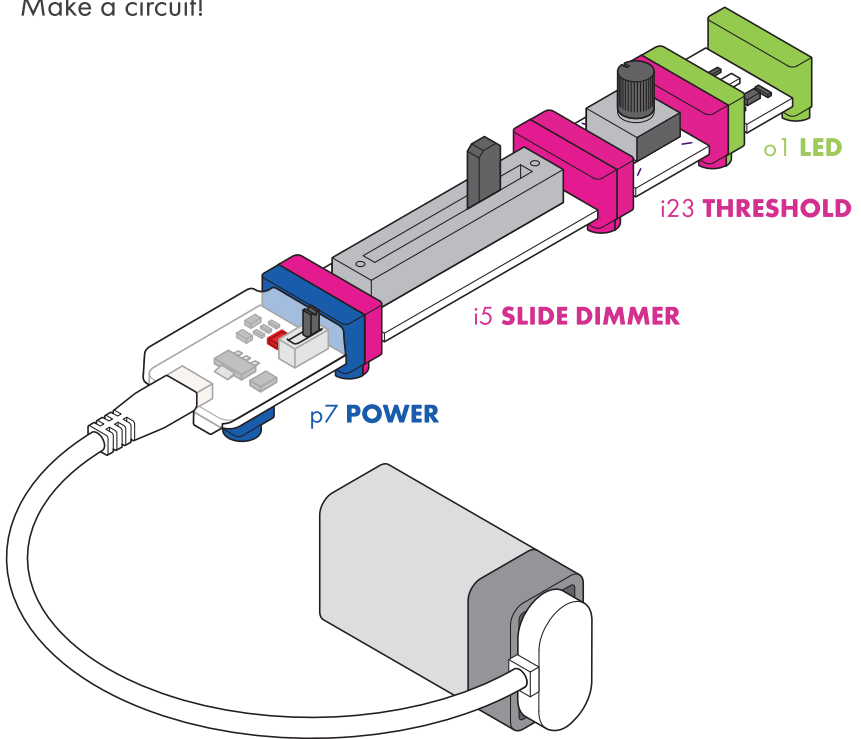



## PLAY

Change the position of the **threshold knob**, then adjust the **slide dimmer** until the **LED Bit** turns **on**.

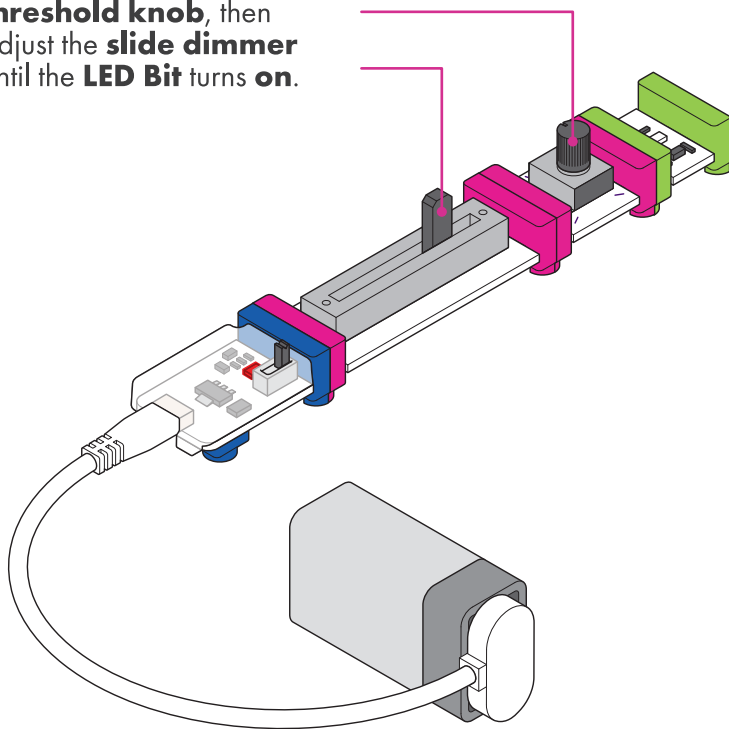

## REMIX

Use the threshold Bit with any of the **sensors** and create a circuit. (e.g. light, sound, temperature, etc.).



## SHARE

Tell someone else what you learned about the **threshold Bit**!

MEET THE BITS 10

# Remote IR Triggering

Explore IR signals with your littleBits.



## CREATE

Make a circuit! You will need an IR remote as well.

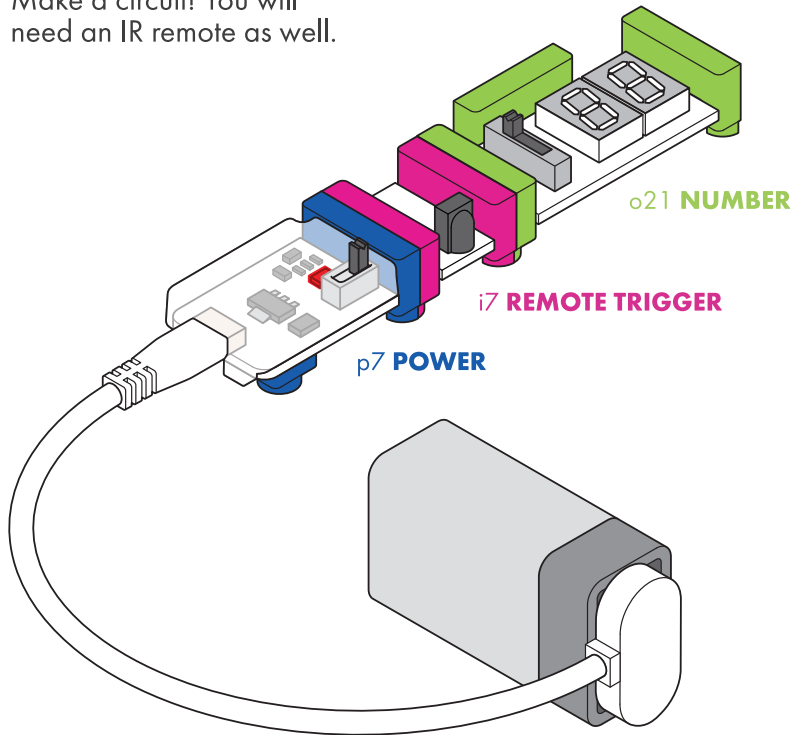



## PLAY

**Experiment** with **IR signals** and learn where you can and can not trigger the Bit from.

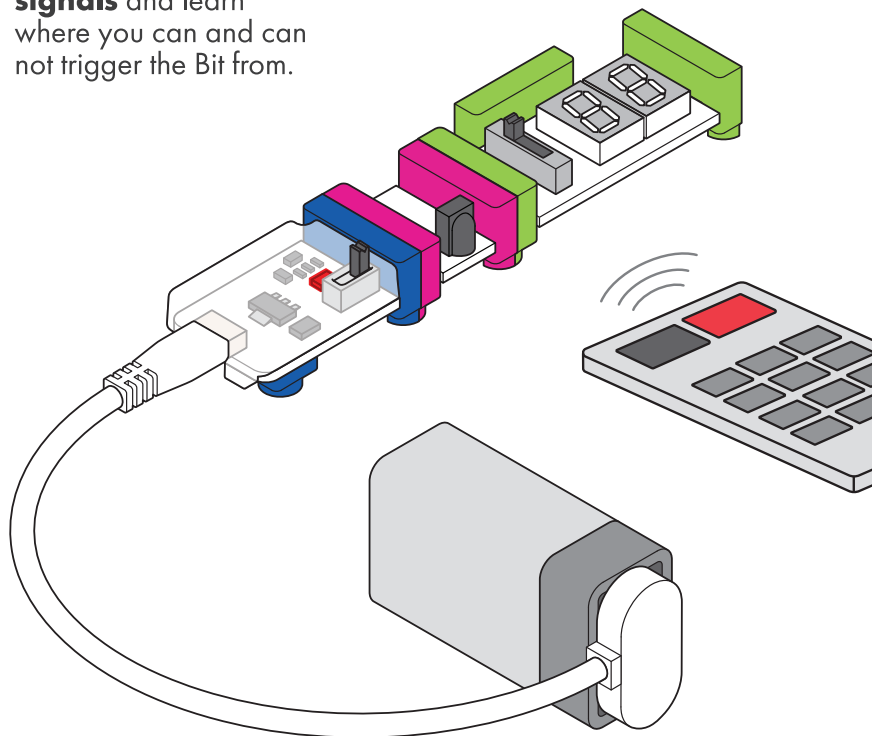

## REMIX

Build a model of an animal that you can trigger with a remote that moves, and has **lights** and/or **sounds**.



## SHARE

Tell someone else what you learned about the **remote trigger Bit!**